



川磊电子科技
ThreeLayer Technologies, Inc.
專業電感製造商

南充新川电子科技有限公司

ThreeLayer Scientific-Technics Co.,Ltd



产品承认书

SPECIFICATION FOR APPROVAL

客户名称 -----
CUSTOMER NAME.

产品类型 High Current Inductor
PRODUCT TYPE

客户料号 -----
CUSTOMER P/N

川磊料号 CLSI-600608 SERIES
OURS P/N

文件编号 SP-21070610
FILE NO.

客户承认/CUSTOMER ACCEPTED		
承认 <i>APPROVED</i>	确认 <i>CHECKED</i>	承办 <i>DESIGN</i>
批注/REMARK		

批准 <i>APPROVED</i>	确认 <i>CHECKED</i>	作成 <i>DESIGN</i>
程志华	陈尧	潘立

生产工厂：南充川磊电子科技有限公司
销售公司：南充新川电子科技有限公司
业务专线：0817-2111163/18681773184
邮 件：threeayer_sales@163.com
地 址：四川省南充市顺庆区潞华工业园区华生东路

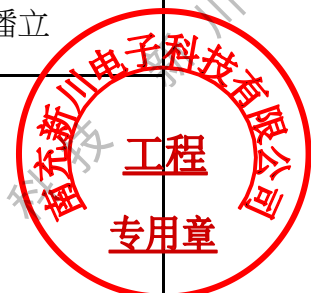

客户名称 CUSTOMER	-----	客户品名 CUSTOMER P/N	-----	版别 REV.	A
产品类型 PRODUCT TYPE	High Current Inductor	新川品名 OURS P/N	CLSI-600608 SERIES	文件编号 FILE NO.	SP-21070610

一.尺寸图/DIMENSION (单位/UNIT : mm)

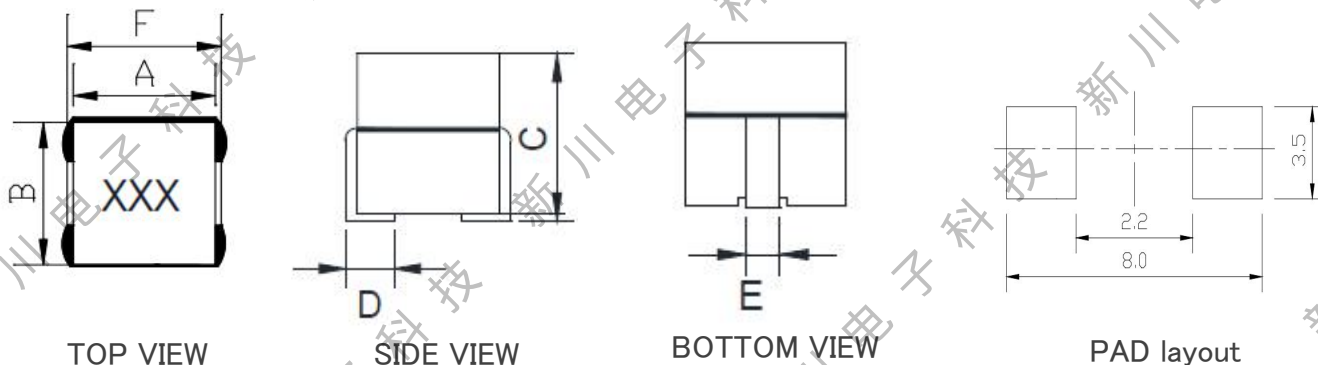

ITEM	A	B	C	D	E	F			
DIM	5.7	5.7	7.5	1.70	3.0	7.0			
TOLE	±0.5	±0.5	±0.5	±0.5	±0.2	±0.5			

二.电路图/CIRCUIT DIAGRAM



三.注意事项/NOTE :

1.印字:黑色

四.电气特性/ELECTRICAL CHARACTERISTIC

Part Number	Inductance (uH)	Tolerance	Test Frequency(Hz)	DCR(mΩ)	IDC1 (A) Max.	IDC2 (A) Max.	MARK
CLSI-600608-R10□	0.1	M N	100K/1V	0.23±7%	40	35	R10
CLSI-600608-R20□	0.2	M N	100K/1V	0.23±7%	22	35	R20

(1) Specify the inductance tolerance, K(±10%),M(±20%),N(±30%)

(2).IDC1:Base on temp.rise & ΔL/L0A 20% typ

(3).IDC2:Temp.rise 40°C Typ

(4).Operating temp.: -40°C to +125°C

(5).Storage temp.: -20°C up to +40°C, 75% RH max.

五.材料清单/MATERIAL LIST

NO.	ITEM	DESCRIPTION
1	CORE	FERRITE
2	CLIP	C1100 P2
3	ADHESIVE	5890
4	INK	WHITE

客户名称 CUSTOMER	-----	客户品名 CUSTOMER P/N	-----	版别 REV.	A
产品类型 PRODUCT TYPE	High Current Inductor	新川品名 OURS P/N	CLSI-600608 SERIES	文件编号 FILE NO.	SP-21070610

六.可靠性测试/RELIABILITY TESTING

Operating Temperature	- 40 to +125 °C (Contain Heating coil)
Appearance Inspection	No external defects by visual inspection
Terminal Strength	After soldering , between copper plaet and terminals of coils , push in two directions of X , Y with standing 10N(1.02kg) for10+/-2 sec. Terminal should not peel off. (Refer to figure at right)
Heat endurance of reflow soldering	Refer to figure
Insulating resistance	Over 100 MΩ at 100V D.C . between wire and core
Dielectric Strength	Apply at 0.5KV 3mA for 1 minute between wire and core
Temperature characteristics	Inductance coefficient (0~2,000) × 10 / °C (- 40~ + 125 °C)
Humidity characteristics	Inductance deviation within ± 10% , after 96 hours in 90~95% relative humidity at 40 ± 2 °C and 1 hours drying under normal condition

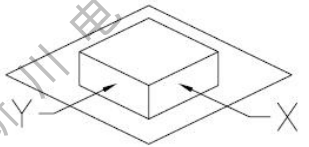

A test is made under the above mentioned condition , and it is kept for 2 hours in the normal

IR Reflow profile

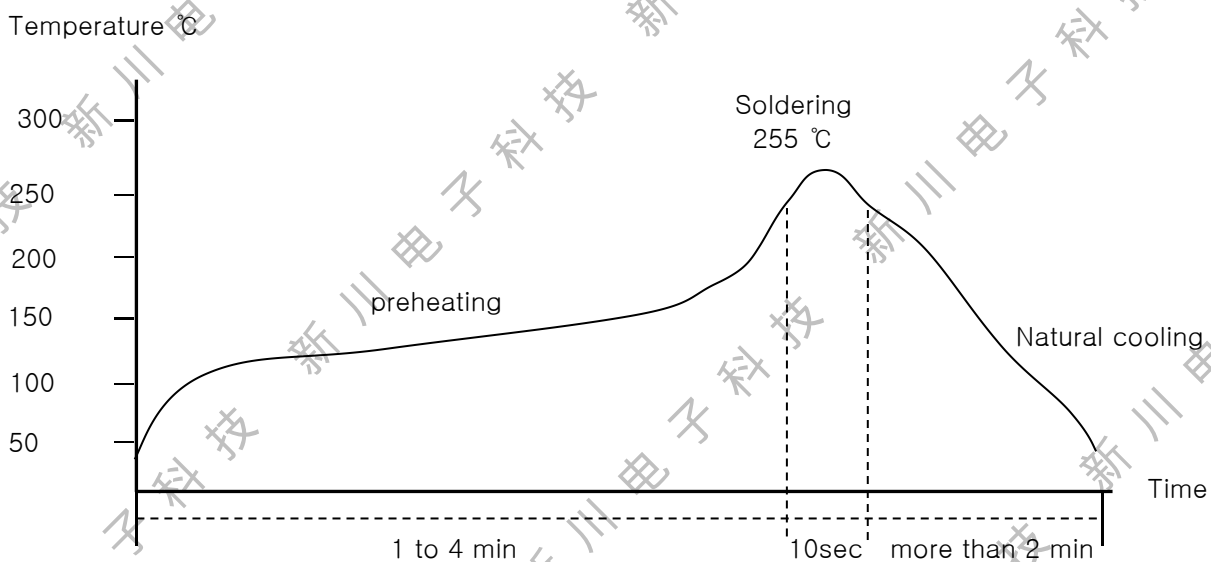

Temperature and humidity . After that , no mechanical and electrical defect should be found .

客户名称 CUSTOMER	-----	客户品名 CUSTOMER P/N	-----	版别 REV.	A
产品类型 PRODUCT TYPE	High Current Inductor	新川品名 OURS P/N	CLSI-600608 SERIES	文件编号 FILE NO.	SP-21070610

七.编带规格/TAPING SPECIFICATIONS

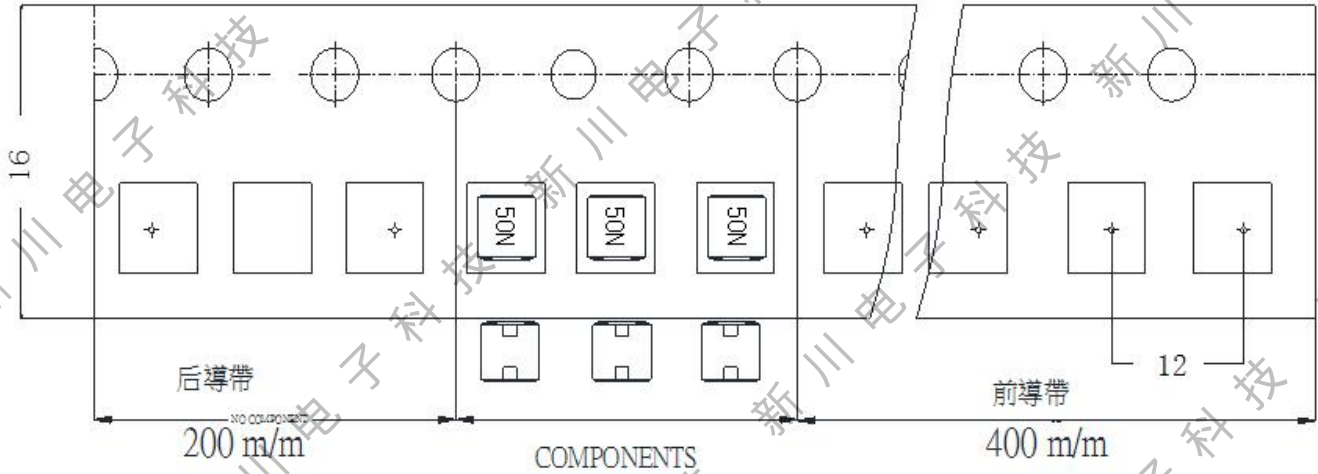

Transparent carrier and cover tape/透明载带和自粘上带

Adhesive strength of cover tape is 20 to 120 gf
The conduction band direction

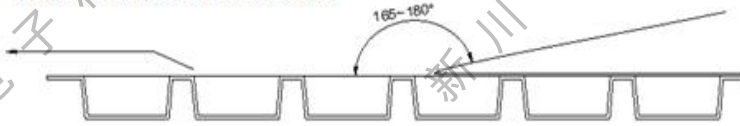

Reel Dimensions (Unit: mm)				Quantity
A	B	C	D	Pcs/Reel
330	100	13	16.5	700

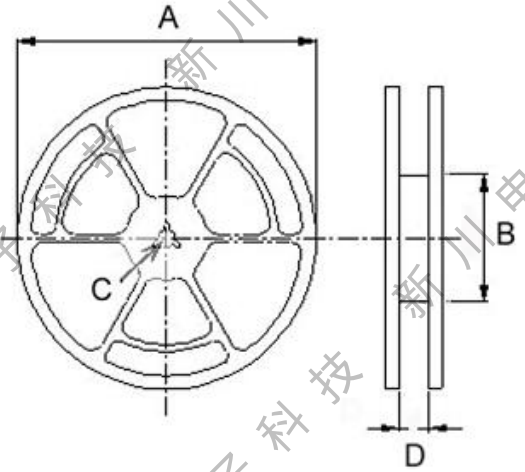

八.包装方式/PACKING LIST

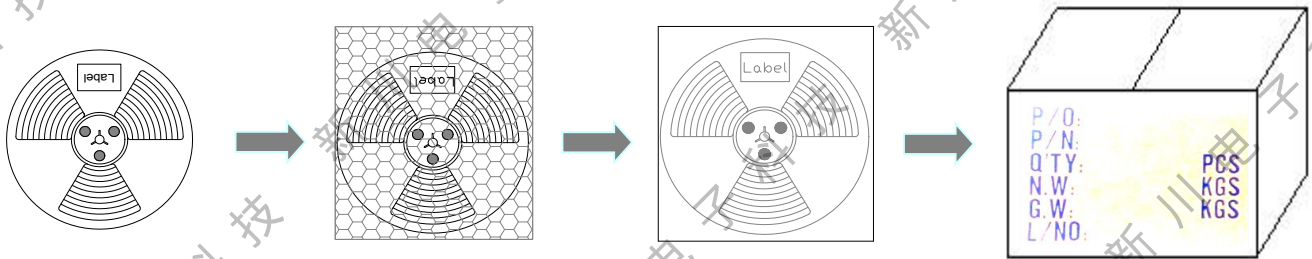

轮盘：13'(直径330mm)
数量：700PCS/盘

PE袋
数量：700PCS/袋

内盒
数量：2100PCS/盒

外箱，数量：10500PCS/箱
不足整箱用内盒或填充物
装满