



川磊电子科技
ThreeLayer Technologies, Inc.
專業電感製造商

南充新川电子科技有限公司

ThreeLayer Scientific-Technics Co.,Ltd



产品承认书

SPECIFICATION FOR APPROVAL

客户名称 -----
CUSTOMER NAME.

产品类型 SMD Power Inductors
PRODUCT TYPE

客户料号 -----
CUSTOMER P/N

川磊料号 CLNR-6020- SERIES
OURS P/N

文件编号 SP-21072150
FILE NO.

客户承认/CUSTOMER ACCEPTED		
承认 APPROVED	确认 CHECKED	承办 DESIGN
批注/REMARK		

批准 APPROVED	确认 CHECKED	作成 DESIGN
程志华	何利	张莉萍

生产工厂：南充川磊电子科技有限公司
销售公司：南充新川电子科技有限公司
业务专线：0817-2111163/18681773184
邮 件：threeayer_sales@163.com
地 址：四川省南充市顺庆区潞华工业园区华生东路

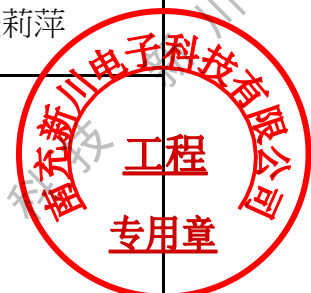

客户名称 CUSTOMER	-----	客户品名 CUSTOMER P/N	-----	版别 REV.	1.0
产品类型 PRODUCT TYPE	SMD Power Inductors	新川品名 OURS P/N	CLNR-6020- SERIES	文件编号 FILE NO.	SP-21072150

一.尺寸图/DIMENSION (单位/UNIT : mm)

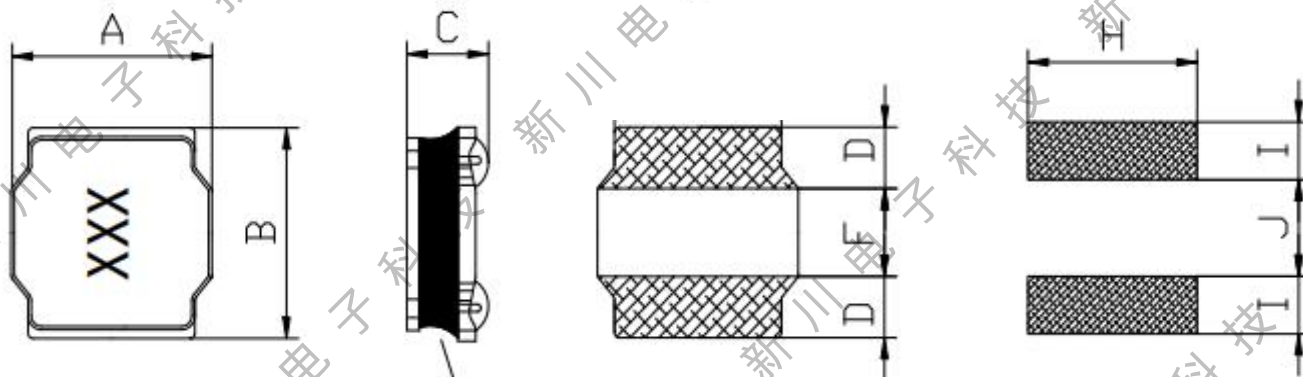

Magnetic shielding

Product size

PAD Layout

ITEM	A	B	C	D	F	H	I	J	
DIM	6.0	6.0	2.1	1.65	2.7	5.3	2.1	2.4	
TOLE	±0.2	±0.2	Max	Typ	Typ	Typ	Typ	Typ	

二.电路图/CIRCUIT DIAGRAM



三.注意事项/NOTE :

1.印字：黑色

四.电气特性/ELECTRICAL CHARACTERISTIC

Part Number	Inductance (uH)	Tolerance	Test Frequency (Hz)	DCR (Ω) ±30%	IDC1 (A) Max.	IDC2 (A) Max.	MARK
CLNR-6020-R68□	0.68	N	100KHZ/1V	0.017	6.55	3.80	R68
CLNR-6020-R82□	0.82	N	100KHZ/1V	0.017	5.30	3.80	R82
CLNR-6020-1R0□	1.0	N	100KHZ/1V	0.020	4.15	3.50	1R0
CLNR-6020-1R5□	1.5	N	100KHZ/1V	0.022	4.25	3.20	1R5
CLNR-6020-2R2□	2.2	M N	100KHZ/1V	0.028	3.75	2.75	2R2
CLNR-6020-3R3□	3.3	M N	100KHZ/1V	0.035	3.15	2.60	3R3
CLNR-6020-4R7□	4.7	M N	100KHZ/1V	0.058	3.00	2.00	4R7

客户名称 CUSTOMER	-----	客户品名 CUSTOMER P/N	-----	版别 REV.	1.0
产品类型 PRODUCT TYPE	SMD Power Inductors	新川品名 OURS P/N	CLNR-6020- SERIES	文件编号 FILE NO.	SP-21072150

四.电气特性/ELECTRICAL CHARACTERISTIC

Part Number	Inductance (uH)	Tolerance	Test Frequency(Hz)	DCR (mΩ) ±30%	IDC1 (A) Max.	IDC2 (A) Max.	MARK
CLNR-6020-6R8□	6.8	M N	100KHZ/1V	0.079	2.20	1.80	6R8
CLNR-6020-100□	10	M N	100KHZ/1V	0.105	1.75	1.40	100
CLNR-6020-120□	12	M N	100KHZ/1V	0.120	1.45	1.30	120
CLNR-6020-150□	15	M N	100KHZ/1V	0.145	1.20	1.20	150
CLNR-6020-180□	18	M N	100KHZ/1V	0.180	1.20	1.08	180
CLNR-6020-220□	22	M N	100KHZ/1V	0.204	1.05	1.00	220
CLNR-6020-330□	33	M N	100KHZ/1V	0.300	0.95	0.84	330
CLNR-6020-470□	47	M N	100KHZ/1V	0.430	0.70	0.80	470

(1) Specify the inductance tolerance, K(±10%),M(±20%),N(±30%)

(2).IDC1:Base on temp.rise & ΔL/L0A 30% Typ

(3).IDC2:Temp.rise 40°C Typ

(4).Operating temp.: -40°C to +125°C

(5).Storage temp.: -20°C up to +40°C, 75% RH max.

五.材料清单/MATERIAL LIST

NO.	ITEM	DESCRIPTION
1	CORE	FERRITE
2	WIRE	P180 G1
3	ADHESIVE	NR-3614
4	TIN	107H
5	INK	BLACK

客户名称 CUSTOMER	-----	客户品名 CUSTOMER P/N	-----	版别 REV.	1.0
产品类型 PRODUCT TYPE	SMD Power Inductors	新川品名 OURS P/N	CLNR-6020- SERIES	文件编号 FILE NO.	SP-21072150

六.可靠性测试/RELIABILITY TESTING

Operating Temperature	- 40 to +125 °C (Contain Heating coil)
Appearance Inspection	No external defects by visual inspection
Terminal Strength	After soldering , between copper plaet and terminals of coils , push in two directions of X , Y with standing 10N(1.02kg) for10+/-2 sec. Terminal should not peel off. (Refer to figure at right)
Heat endurance of reflow soldering	Refer to figure
Insulating resistance	Over 100 MΩ at 100V D.C . between wire and core
Dielectric Strength	Apply at 0.5KV 3mA for 1 minute between wire and core
Temperature characteristics	Inductance coefficient (0~2,000) × 10 / °C (- 40~ + 125 °C)
Humidity characteristics	Inductance deviation within ± 10% , after 96 hours in 90~95% relative humidity at 40 ± 2 °C and 1 hours drying under normal condition

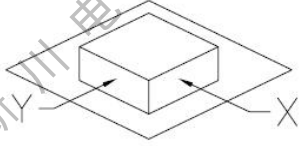

A test is made under the above mentioned condition , and it is kept for 2 hours in the normal

IR Reflow profile

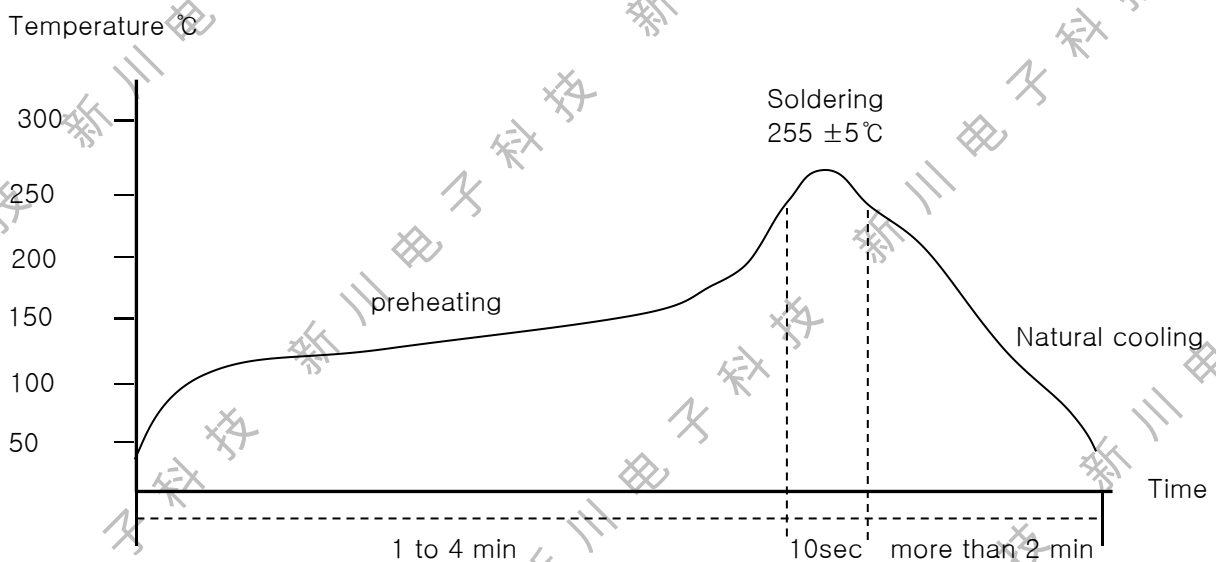

Temperature and humidity . After that , no mechanical and electrical defect should be found .

客户名称 CUSTOMER	-----	客户品名 CUSTOMER P/N	-----	版别 REV.	1.0
产品类型 PRODUCT TYPE	SMD Power Inductors	新川品名 OURS P/N	CLNR-6020- SERIES	文件编号 FILE NO.	SP-21072150

七.编带规格/TAPING SPECIFICATIONS

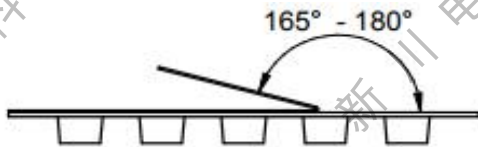
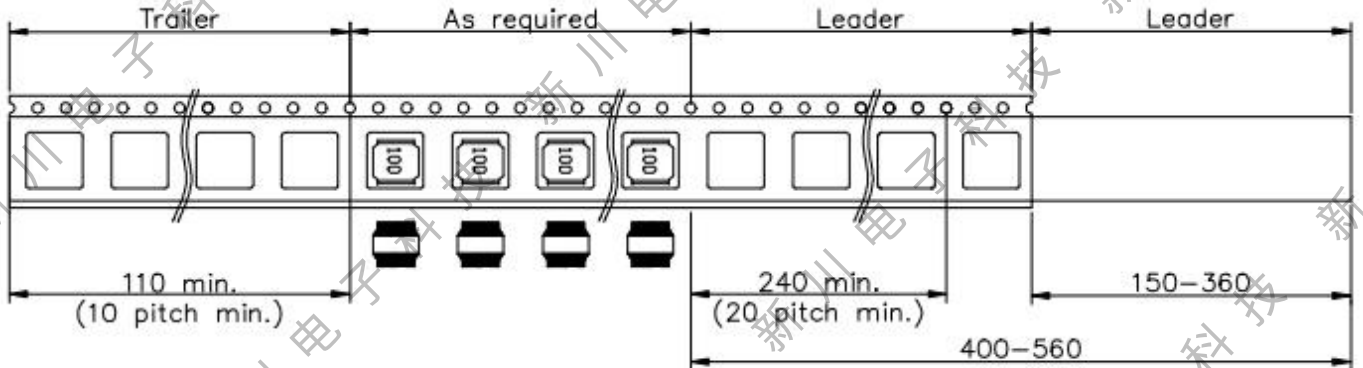

Tape width	Distance	Pull-of force
16 mm	8 mm	10~120g

八.包装方式/PACKING LIST

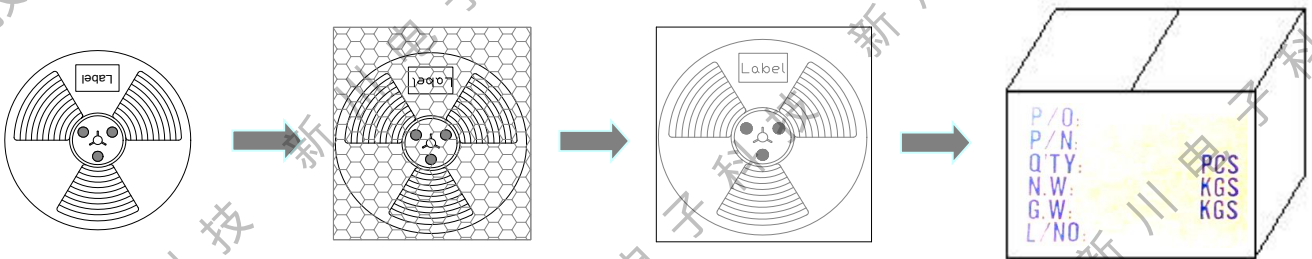

轮盘：13'(直径330mm)
数量：2500PCS/盘

PE袋
数量：2500PCS/袋

内盒
数量：7500PCS/盒

外箱，数量：37500PCS/箱
不足整箱用内盒或填充物
装满