



川磊电子科技
ThreeLayer Technologies, Inc.
專業電感製造商

南充新川电子科技有限公司

ThreeLayer Scientific-Technics Co.,Ltd



产品承认书

SPECIFICATION FOR APPROVAL

| | |
|------------------------------|--------------------------|
| 客户名称 <i>CUSTOMER NAME</i> | ----- |
| 产品类型 <i>PRODUCT TYPE</i> | Shielded Power Inductors |
| 客户料号 <i>CUSTOMER P/N</i> | ----- |
| 川磊料号 <i>OURS P/N</i> | CDRI-5020F SERIES |
| 文件编号 <i>FILE NO.</i> | SP-18121703 |

| | | |
|------------------------|----------------------|---------------------|
| 客户承认/CUSTOMER ACCEPTED | | |
| 承认 <i>APPROVED</i> | 确认 <i>CHECKED</i> | 承办 <i>DESIGN</i> |
| | | |
| 批注/REMARK | | |

| | | |
|-----------------------|----------------------|---------------------|
| 批准 <i>APPROVED</i> | 确认 <i>CHECKED</i> | 作成 <i>DESIGN</i> |
| 程志华 | 陈尧 | 潘立 |

生产工厂：南充川磊电子科技有限公司
 销售公司：南充新川电子科技有限公司
 业务专线：0817-2111163/18681773184
 邮 件：threeayer_sales@163.com
 地 址：四川省南充市顺庆区潞华工业园区华生东路

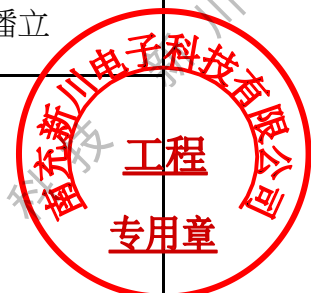

| | | | | | |
|----------------------|--------------------------|----------------------|-------------------|------------------|-------------|
| 客户名称 CUSTOMER | ----- | 客户品名 CUSTOMER P/N | ----- | 版别 REV. | A |
| 产品类型 PRODUCT TYPE | Shielded Power Inductors | 新川品名 OURS P/N | CDRI-5020F SERIES | 文件编号 FILE NO. | SP-18121703 |

一.尺寸图/DIMENSION (单位/UNIT : mm)

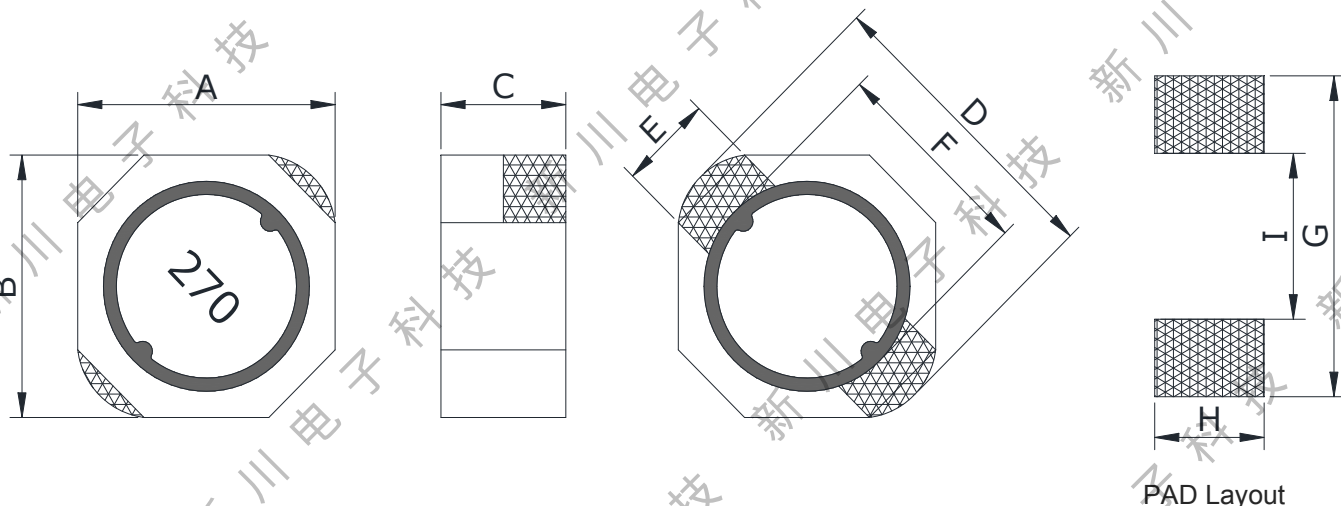

| | | | | | | | | | |
|------|------|------|-----|-----|-----|-----|-----|-----|-----|
| ITEM | A | B | C | D | E | F | G | H | I |
| DIM | 5.0 | 5.0 | 2.0 | 6.2 | 1.7 | 4.2 | 6.0 | 2.0 | 4.0 |
| TOLE | ±0.3 | ±0.3 | Max | Max | Typ | Typ | Typ | Typ | Typ |

二.电路图/CIRCUIT DIAGRAM

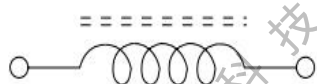

三.注意事项/NOTE :

1.印字 : 白色Gulim字体 , 2.0x1.7mm

四.电气特性/ELECTRICAL CHARACTERISTIC

| Part Number | INDUCTANCE (uH) | TEST FREQ. (Hz) | DCR (mΩ) Max. | IDC1 (A) Max. | IDC2 (A) Max. | MARK |
|-----------------|-----------------|-----------------|---------------|---------------|---------------|------|
| CDRI-5020F-1R2N | 1.2 ±30% | 100K/0.25V | 44 | 2.15 | 2.87 | 1R2 |
| CDRI-5020F-2R2N | 2.2 ±30% | 100K/0.25V | 59 | 1.63 | 2.06 | 2R2 |
| CDRI-5020F-3R5N | 3.5 ±30% | 100K/0.25V | 73 | 1.34 | 1.82 | 3R5 |
| CDRI-5020F-4R7N | 4.7 ±30% | 100K/0.25V | 87 | 1.14 | 1.54 | 4R7 |
| CDRI-5020F-6R8N | 6.8 ±30% | 100K/0.25V | 105 | 0.95 | 1.38 | 6R8 |
| CDRI-5020F-100M | 10.0 ±20% | 100K/0.25V | 150 | 0.76 | 1.10 | 100 |
| CDRI-5020F-150M | 15.0 ±20% | 100K/0.25V | 210 | 0.63 | 0.91 | 150 |
| CDRI-5020F-220M | 22.0 ±20% | 100K/0.25V | 275 | 0.56 | 0.83 | 220 |
| CDRI-5020F-330M | 33.0 ±20% | 100K/0.25V | 455 | 0.44 | 0.61 | 330 |
| CDRI-5020F-470M | 47.0 ±20% | 100K/0.25V | 730 | 0.36 | 0.45 | 470 |

| | | | | | |
|----------------------|--------------------------|----------------------|-------------------|------------------|-------------|
| 客户名称 CUSTOMER | ----- | 客户品名 CUSTOMER P/N | ----- | 版别 REV. | A |
| 产品类型 PRODUCT TYPE | Shielded Power Inductors | 新川品名 OURS P/N | CDRI-5020F SERIES | 文件编号 FILE NO. | SP-18121703 |

六.可靠性测试/RELIABILITY TESTING

| | |
|------------------------------------|---|
| Operating Temperature | - 40 to +125 °C (Contain Heating coil) |
| Appearance Inspection | No external defects by visual inspection |
| Terminal Strength | After soldering , between copper plaet and terminals of coils , push in two directions of X , Y with standing 10N(1.02kg) for10+/-2 sec. Terminal should not peel off. (Refer to figure at right) |
| Heat endurance of reflow soldering | Refer to figure |
| Insulating resistance | Over 100 MΩ at 100V D.C . between wire and core |
| Dielectric Strength | Apply at 0.5KV 3mA for 1 minute between wire and core |
| Temperature characteristics | Inductance coefficient (0~2,000) × 10 / °C (- 40~ + 125 °C) |
| Humidity characteristics | Inductance deviation within ± 10% , after 96 hours in 90~95% relative humidity at 40 ± 2 °C and 1 hours drying under normal condition |

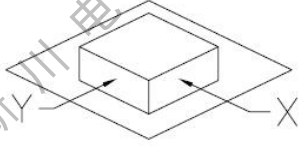

A test is made under the above mentioned condition , and it is kept for 2 hours in the normal

IR Reflow profile

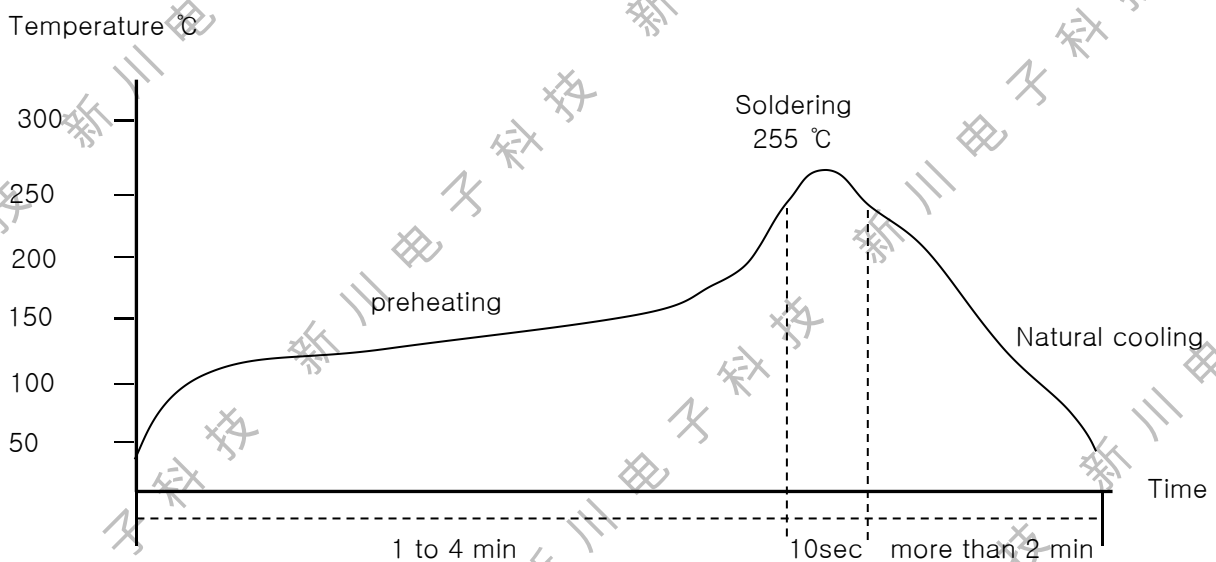

Temperature and humidity . After that , no mechanical and electrical defect should be found .

| | | | | | |
|----------------------|--------------------------|----------------------|-------------------|------------------|-------------|
| 客户名称 CUSTOMER | ----- | 客户品名 CUSTOMER P/N | ----- | 版别 REV. | A |
| 产品类型 PRODUCT TYPE | Shielded Power Inductors | 新川品名 OURS P/N | CDRI-5020F SERIES | 文件编号 FILE NO. | SP-18121703 |

七.编带规格/TAPING SPECIFICATIONS

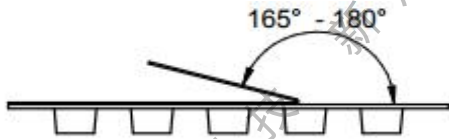
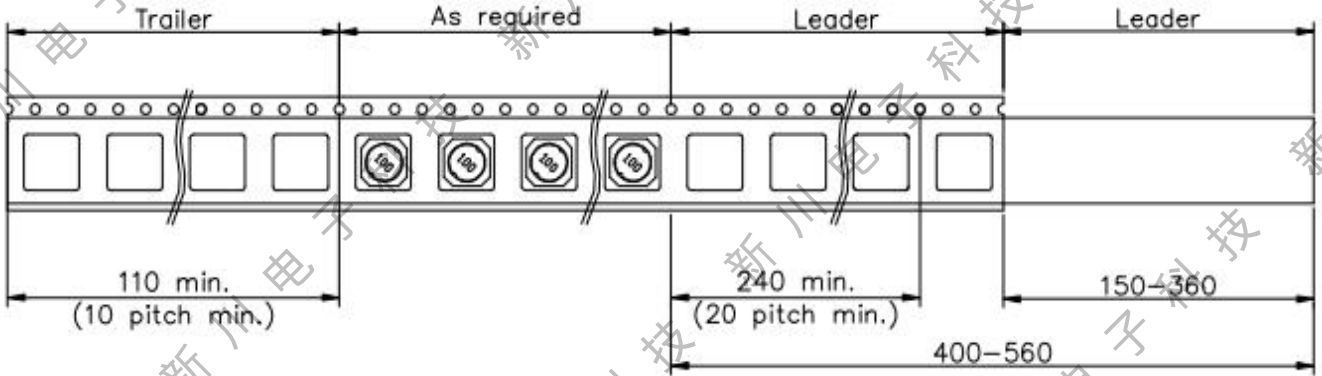

| Tape width | Distance | Pull-of force |
|------------|----------|---------------|
| 12 mm | 8 mm | 10~120g |

八.包装方式/PACKING LIST

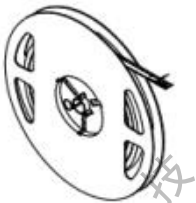

轮盘：7'(直径178mm)
数量：900PCS/盘

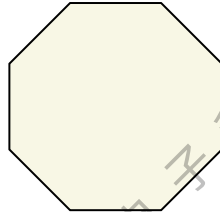

内盒/PE袋
数量：3600PCS/盒

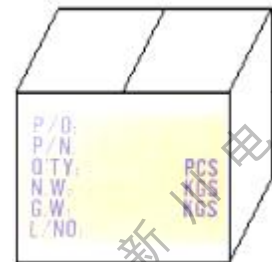

外箱：数量：36000PCS/箱
不足整箱用内盒或填充物装满