



川磊电子科技
ThreeLayer Technologies, Inc.
專業電感製造商

南充新川电子科技有限公司

ThreeLayer Scientific-Technics Co.,Ltd



产品承认书

SPECIFICATION FOR APPROVAL

客户名称 -----
CUSTOMER NAME.

产品类型 Shielded Power Inductors
PRODUCT TYPE

客户料号 -----
CUSTOMER P/N

川磊料号 CLPS-6012 SERIES
OURS P/N

文件编号 SP-21070605
FILE NO.

客户承认/CUSTOMER ACCEPTED		
承认 APPROVED	确认 CHECKED	承办 DESIGN
批注/REMARK		

批准 APPROVED	确认 CHECKED	作成 DESIGN
程志华	陈尧	潘立

生产工厂：南充川磊电子科技有限公司
销售公司：南充新川电子科技有限公司
业务专线：0817-2111163/18681773184
邮 件：threeayer_sales@163.com
地 址：四川省南充市顺庆区潞华工业园区华生东路

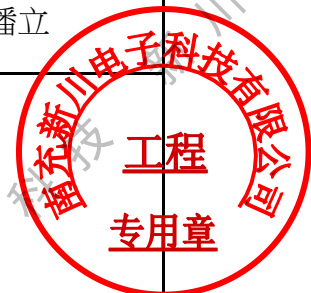

客户名称 CUSTOMER	-----	客户品名 CUSTOMER P/N	-----	版别 REV.	A
产品类型 PRODUCT TYPE	Shielded Power Inductors	新川品名 OURS P/N	CLPS-6012 SERIES	文件编号 FILE NO.	SP-21070605

一.尺寸图/DIMENSION (单位/UNIT : mm)

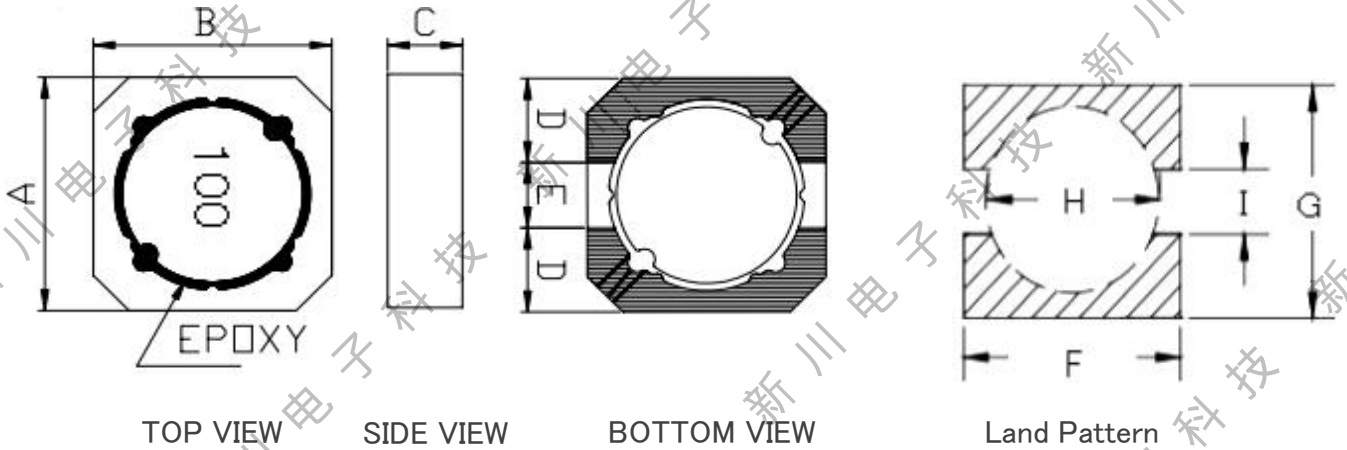

ITEM	A	B	C	D	E	F	G	H	I
DIM	6.0	6.0	1.2	2.0	2.0	6.6	6.6	4.6	2.0
TOLE	±0.2	±0.2	Max	Typ	Typ	Typ	Typ	Typ	Typ

二.电路图/CIRCUIT DIAGRAM

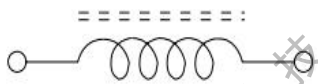

三.注意事项/NOTE :

1.印字：白色Gulim字体

四.电气特性/ELECTRICAL CHARACTERISTIC

Part Number	Inductance (uH)	Tolerance	Test Frequency (Hz)	DCR (mΩ) Max	IDC1 (A) Max.	IDC2 (A) Max.	MARK
CLPS-6012-2R2□	2.0	N	100K/0.1V	70	2.3	2.3	2R2
CLPS-6012-2R5□	2.3	N	100K/0.1V	70	2.3	2.3	2R5
CLPS-6012-3R0□	3	N	100K/0.1V	81	2	2	3R0
CLPS-6012-3R3□	3.3	N	100K/0.1V	90	1.9	1.9	3R3
CLPS-6012-3R9□	3.9	N	100K/0.1V	100	1.7	1.7	3R9
CLPS-6012-4R7□	4.7	N	100K/0.1V	130	1.6	1.5	4R7
CLPS-6012-5R6□	5.6	N	100K/0.1V	145	1.5	1.4	5R6
CLPS-6012-6R8□	6.8	M N	100K/0.1V	165	1.4	1.3	6R8
CLPS-6012-8R2□	8.2	M N	100K/0.1V	200	1.2	1.2	8R2
CLPS-6012-100□	10	M N	100K/0.1V	240	1.0	1.0	100
CLPS-6012-150□	15	M N	100K/0.1V	300	0.8	0.7	150

客户名称 CUSTOMER	-----	客户品名 CUSTOMER P/N	-----	版别 REV.	A
产品类型 PRODUCT TYPE	Shielded Power Inductors	新川品名 OURS P/N	CLPS-6012 SERIES	文件编号 FILE NO.	SP-21070605

四.电气特性/ELECTRICAL CHARACTERISTIC

Part Number	Inductance (uH)	Tolerance	Test Frequency (Hz)	DCR (mΩ) Max	IDC1 (A) Max.	IDC2 (A) Max.	MARK
CLPS-6012-220□	22	M N	100K/0.1V	400	0.75	0.65	220
CLPS-6012-330□	33	M N	100K/0.1V	570	0.65	0.6	330
CLPS-6012-470□	47	M N	100K/0.1V	750	0.6	0.55	470
CLPS-6012-101□	100	M	100K/0.1V	1250	0.3	0.3	101

(1).Specify the inductance tolerance, K(±10%), L(±15%), M(±20%),N(±30%)

(2).IDC1:Base on temp.rise & $\Delta L/L0A \leq 30\%$ MAX

(3).IDC2:Temp.rise 40°C Typ

(4).Operating temp.: -40°C to +125°C

(5).Storage temp.: -20°C up to +40°C, 75% RH max.

五.材料清单/MATERIAL LIST

NO.	ITEM	DESCRIPTION
1	CORE	FERRITE
2	WIRE	P180 Grd1
3	ADHESIVE	XNR3614
4	INK	WHITE

客户名称 CUSTOMER	-----	客户品名 CUSTOMER P/N	-----	版别 REV.	A
产品类型 PRODUCT TYPE	Shielded Power Inductors	新川品名 OURS P/N	CLPS-6012 SERIES	文件编号 FILE NO.	SP-21070605

六.可靠性测试/RELIABILITY TESTING

Operating Temperature	- 40 to +125 °C (Contain Heating coil)
Appearance Inspection	No external defects ,by visual inspection
Terminal Strength	After soldering , between copper plaet and terminals of coils , push in two directions of X , Y with standing 10N(1.02kg) for10+/-2 sec. Terminal should not peel off. (Refer to figure at right)
Heat endurance of reflow soldering	Refer to figure
Insulating resistance	Over 100 MΩ at 100V D.C . between wire and core
Dielectric Strength	Apply at 0.5KV 3mA for 1 minute between wire and core
Temperature characteristics	Inductance coefficient (0~2,000) × 10 / °C (- 40~ + 125 °C)
Humidity characteristics	Inductance deviation within ± 10% , after 96 hours in 90~95% relative humidity at 40 ± 2 °C and 1 hours drying under normal condition

A test is made under the above mentioned condition , and it is kept for 2 hours in the normal

IR Reflow profile

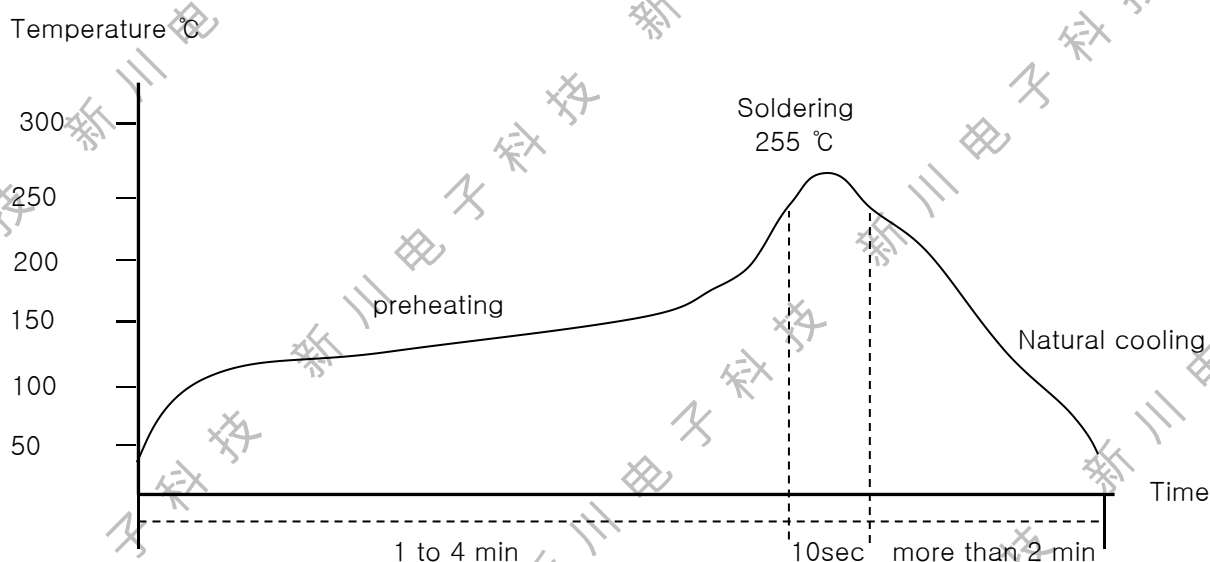

Temperature and humidity . After that , no mechanical and electrical defect should be found .

客户名称 CUSTOMER	-----	客户品名 CUSTOMER P/N	-----	版别 REV.	A
产品类型 PRODUCT TYPE	Shielded Power Inductors	新川品名 OURS P/N	CLPS-6012 SERIES	文件编号 FILE NO.	SP-21070605

七.编带规格/TAPING SPECIFICATIONS

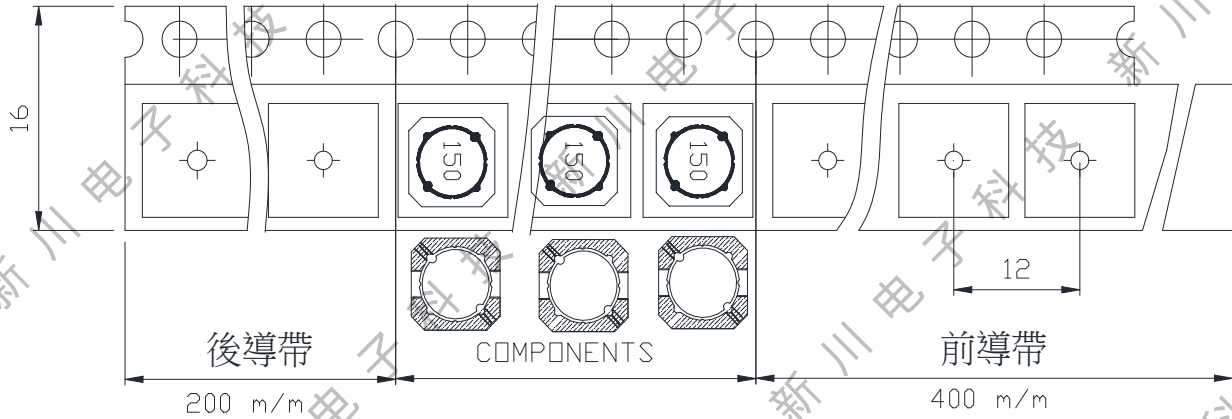

Transparent carrier and cover tape/透明载带和自粘上带

Adhesive strength of cover tape is 20 to 120 gf
The conduction band direction

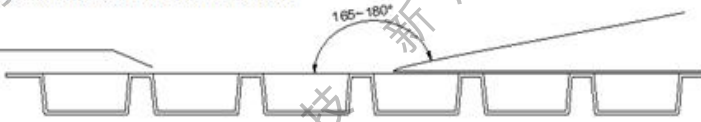

Reel Dimensions (Unit: mm)				Quantity
A	B	C	D	Pcs/Reel
330	100	13	16.5	2000

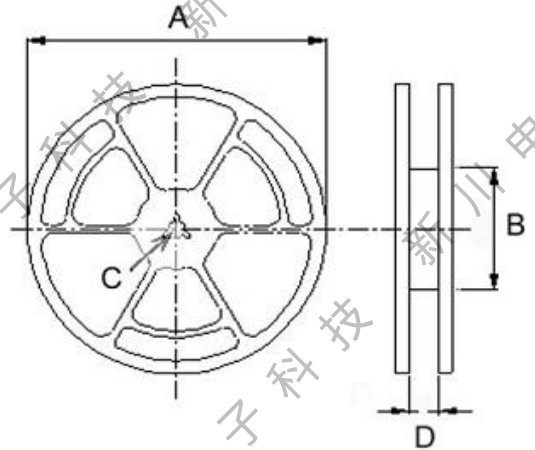

八.包装方式/PACKING LIST

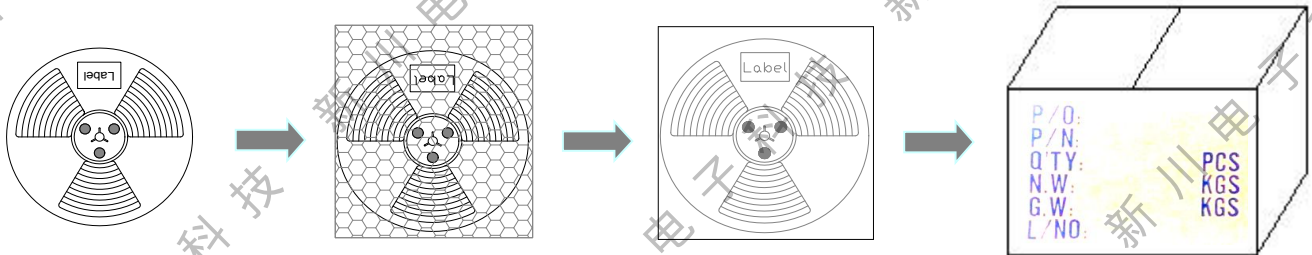

轮盘：13'(直径330mm)
数量：3000PCS/盘

PE袋
数量：3000PCS/袋

内盒
数量：9000PCS/盒

外箱，数量：45000PCS/箱
不足整箱用内盒或填充物
装满