



川磊电子科技  
ThreeLayer Technologies, Inc.  
專業電感製造商

南充新川电子科技有限公司

ThreeLayer Scientific-Technics Co.,Ltd



产品承认书

SPECIFICATION FOR APPROVAL

客户名称 <i>CUSTOMER NAME.</i>	----
产品类型 <i>PRODUCT TYPE</i>	Shielded Power Inductors
客户料号 <i>CUSTOMER PN</i>	----
川磊料号 <i>OURS PN</i>	CDRI-105A- SERIES
文件编号 <i>FILE NO.</i>	SP-21070613

客户承认/ <i>CUSTOMER ACCEPTED</i>		
承认 <i>APPROVED</i>	确认 <i>CHECKED</i>	承办 <i>DESIGN</i>
批注/ <i>REMARK</i>		

批准 <i>APPROVED</i>	确认 <i>CHECKED</i>	作成 <i>DESIGN</i>
程志华	陈尧	潘立

生产工厂：南充川磊电子科技有限公司  
销售公司：南充新川电子科技有限公司  
业务专线：0817-2111163/18681773184  
邮 件：threelayer\_sales@163.com  
地 址：四川省南充市顺庆区潞华工业园区华生东路

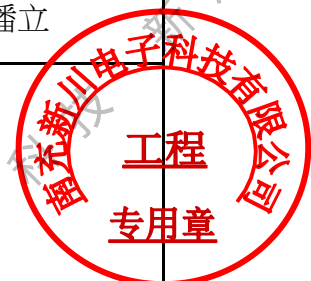



客户名称 CUSTOMER	---	客户品名 CUSTOMER P/N	---	版别 REV.	1.0
产品类型 PRODUCT TYPE	Shielded Power Inductors	川磊品名 OURS P/N	CDRI-105A- SERIES	文件编号 FILE NO.	SP-21070613

一.尺寸图/DIMENSION (单位/UNIT : mm)

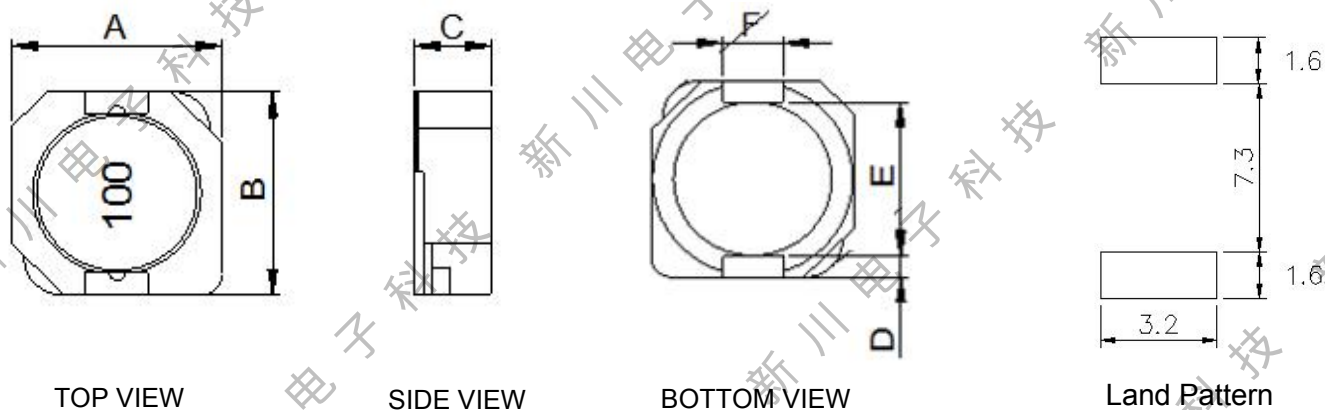

ITEM	A	B	C	D	E	F		
DIM	10.1	10.3	5.1	1.2	7.7	3.0		
TOLE	±0.5	±0.5	Max	TYP	TYP	TYP		

二.电路图/CIRCUIT DIAGRAM

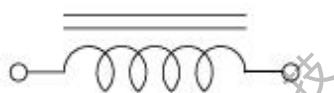

三.注意事项/NOTE :

1.印字：黑色

四.电气特性/ELECTRICAL CHARACTERISTIC

Part Number	Inductance (uH)	Tolerance	Test Frequency (Hz)	DCR (mΩ) Max	IDC1 (A) Max.	IDC2 (A) Max.	MARK
CDRI-105A-1R3□	1.3	N	100K/1V	9.8	15	15	1R3
CDRI-105A-1R5□	1.5	N	100K/1V	9.8	15	10	1R5
CDRI-105A-3R5□	3.5	N	100K/1V	15.5	7	6.5	3R5
CDRI-105A-4R7□	4.7	M N	100K/1V	16	6.5	6.0	4R7
CDRI-105A-5R6□	5.6	M N	100K/1V	17.8	6.3	5.6	5R6
CDRI-105A-6R8□	6.8	M N	100K/1V	18	6.0	5.4	6R8
CDRI-105A-8R2□	8.2	M N	100K/1V	20	5.5	5.0	8R2
CDRI-105A-100□	10	M N	100K/1V	26	5.0	4.5	100
CDRI-105A-120□	12	M N	100K/1V	33	4.5	4.0	120
CDRI-105A-150□	15	M N	100K/1V	41	4.2	3.3	150

客户名称 CUSTOMER	----	客户品名 CUSTOMER P/N	----	版别 REV.	1.0
产品类型 PRODUCT TYPE	Shielded Power Inductors	川磊品名 OURS P/N	CDRI-105A- SERIES	文件编号 FILE NO.	SP-21070613

四.电气特性/ELECTRICAL CHARACTERISTIC

Part Number	Inductance (uH)	Tolerance	Test Frequency (Hz)	DCR (mΩ) Max	IDC1 (A) Max.	IDC2 (A) Max.	MARK
CDRI-105A-330□	33	M N	100K/1V	84	3.4	3.00	330
CDRI-105A-470□	47	M N	100K/1V	130	3.0	2.50	470
CDRI-105A-221□	220	K M	100K/1V	500	1.0	1.00	221

(1).Specify the inductance tolerance, K(±10%), L(±15%), M(±20%),N(±30%)

(2).IDC1:Base on temp.rise &  $\Delta L/L0A \leq 35\%$  MAX

(3).IDC2:Temp.rise 45°C Typ

(4).Operating temp.: -40°C to +125°C

(5).Storage Temp: -20°C up to +40°C, 75% RH max.

五.材料清单/MATERIAL LIST

NO.	ITEM	DESCRIPTION
1	CORE	FERRITE
2	WIRE	P180 Grd1
3	CLIP	C1100 P2
4	SOLDER	Sn99.3:Cu0.7
5	ADHESIVE	G-500HF
		FW-6013
6	INK	BLACK

客户名称 CUSTOMER	----	客户品名 CUSTOMER P/N	----	版别 REV.	1.0
产品类型 PRODUCT TYPE	Shielded Power Inductors	川磊品名 OURS P/N	CDRI-105A- SERIES	文件编号 FILE NO.	SP-21070613

六.可靠性测试/RELIABILITY TESTING

Operating Temperature	- 40 to +125 °C ( Contain Heating coil )
Appearance Inspection	No external defects by visual inspection
Terminal Strength	After soldering , between copper plaet and terminals of coils , push in two directions of X , Y with standing 10N(1.02kg) for10+/-2 sec. Terminal should not peel off. ( Refer to figure at right )
Heat endurance of reflow soldering	Refer to figure
Insulating resistance	Over 100 MΩ at 100V D.C . between wire and core
Dielectric Strength	Apply at 0.5KV 3mA for 1 minute between wire and core
Temperature characteristics	Inductance coefficient ( 0~2,000 ) × 10 / °C ( - 40~ + 125 °C )
Humidity characteristics	Inductance deviation within ± 10% , after 96 hours in 90~95% relative humidity at 40 ± 2 °C and 1 hours drying under normal condition

A test is made under the above mentioned condition , and it is kept for 2 hours in the normal

IR Reflow profile

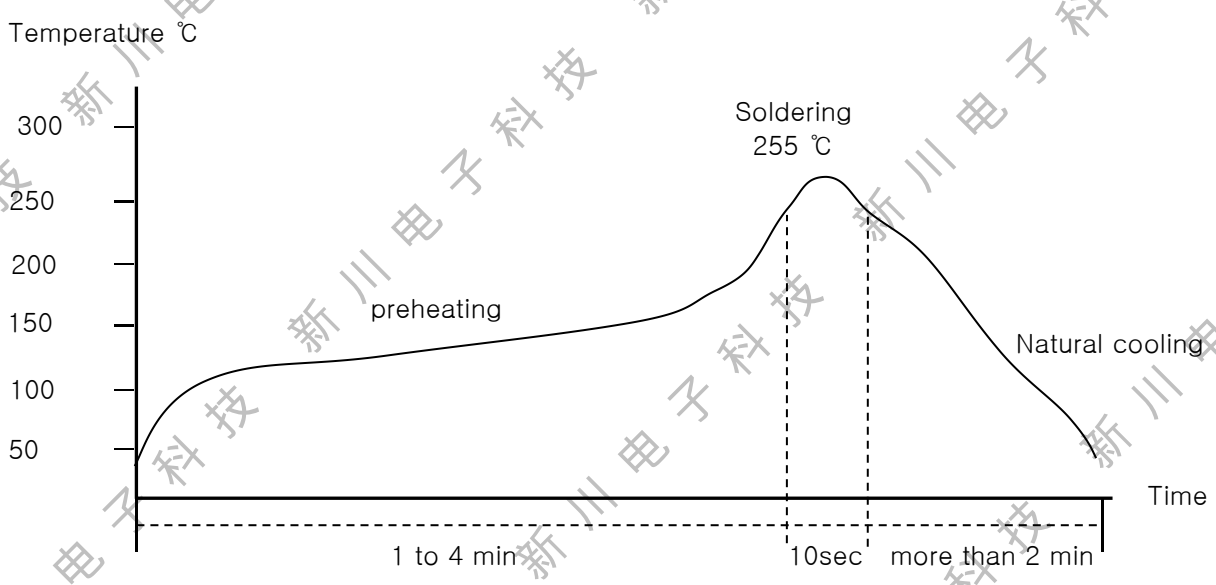

Temperature and humidity . After that , no mechanical and electrical defect should be found .

客户名称 CUSTOMER	----	客户品名 CUSTOMER P/N	----	版别 REV.	1.0
产品类型 PRODUCT TYPE	Shielded Power Inductors	川磊品名 OURS P/N	CDRI-105A- SERIES	文件编号 FILE NO.	SP-21070613

七.包装方式/PACKING LIST

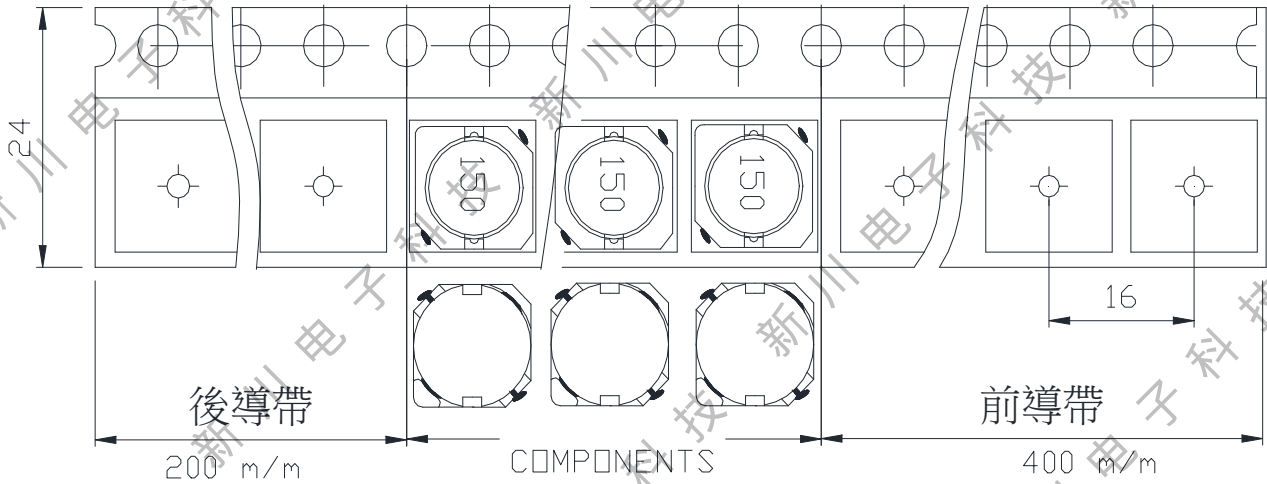

Transparent carrier and cover tape/透明载带和自粘上带

Tape width	Distance	Pull-of force
24 mm	16 mm	20~100g

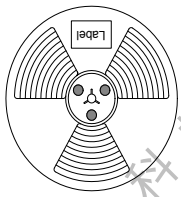
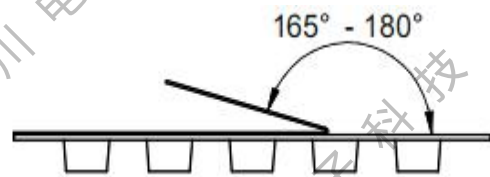

轮盘：13'(直径330mm)  
数量：700PCS/盘

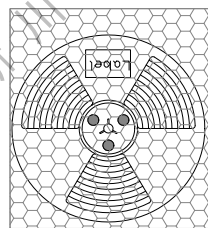

PE袋  
数量：700PCS/袋

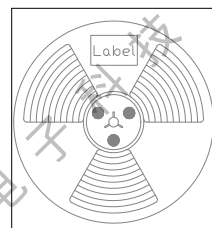

内盒  
数量：1400PCS/盒

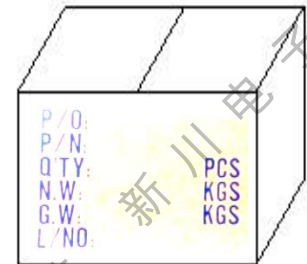

外箱，数量：7000PCS/箱  
不足整箱用内盒或填充物  
装满